

Drinking water / Industrial water

Construction

Welded shell in clean steel plate all side to sand-blast, internal and external rust protection with different paint protective coats. Inside painted 320 µm, outside painted standard RAL 5015, other RAL-paints on request. Butyl bladder. Other bladder materials, complete execution and connection in stainless steel on request.

System

The liquid circulates in the bladder and is only in contact with the bladder and flange connection.

Working pressure

25 bar

Precharge pressure P0

According to calculation ORELL Tec AG.

Temperature range

Standard execution 0 °C to +80 °C
Other ranges on request.

Pressure liquids

Water
Other liquids should be specified with the order.

Mounting / mounting instruction

Vertical on 3 legs.
Leave a free space of 1000 mm over the manhole for removal and installation of the bladder.

Accessories

LED Water Level Display see data sheet OLD 1120 in chapter 11 "Accessories".

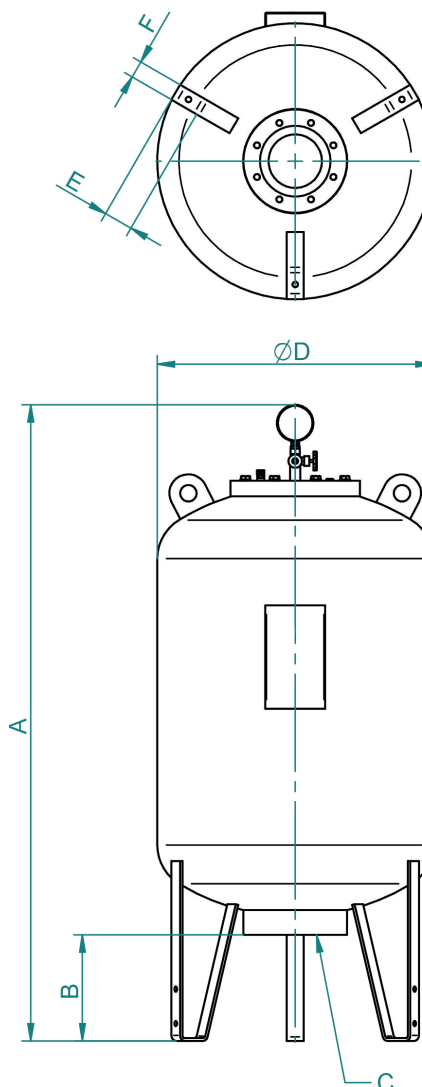

Type	Gasvol. V0 liter	Weight kg	Dimensions in mm				Possible connections C in PN 25	Size B
			A	D	E	F		
DDV 100 – 25 / 90	106	111	1275	510	54	50	1" IG	275 – 285 mm
DDV 200 – 25 / 90	208	162	1795	510	54	50	1" IG	275 – 285 mm
DDV 300 – 25 / 90	315	277	1895	600	54	50	DN 50	275 – 285 mm
DDV 500 – 25 / 90	519	335	1825	800	54	50	DN 50	275 – 285 mm
DDV 750 – 25 / 90	774	478	2035	900	100	100	DN 50	275 – 285 mm
DDV 1000 – 25 / 90	1029	605	2445	900	100	100	DN 50	275 – 285 mm
DDV 1500 – 25 / 90*	1550	921	2610	1100	100	100	DN 80	275 – 285 mm
DDV 2000 – 25 / 90*	2050	1140	3145	1100	100	100	DN 80	275 – 285 mm
DDV 3000 – 25 / 90*	3075	1615	3345	1300	100	100	DN 80	275 – 285 mm
DDV 4000 – 25 / 90*	4100	2060	3375	1500	150	150	DN 80	275 – 285 mm
DDV 5000 – 25 / 90*	5120	2366	3955	1500	150	150	DN 80	275 – 285 mm

*with lateral nitrogen line